

JA-60V Wireless outdoor P.I.R. motion detector

The JA-60V is an outdoor intruder detector designed to detect human body movement in a protected area. Used PIR detector produced by Optex has two double-layered detection patterns (upper and lower) both have to be activated to trigger the alarm. This reduces false alarms, particularly those caused by temperature changes, light reflection or small animals.

A tamper triggers an alarm if there is any attempt to tamper with the detector.

The built-in transmitter is fully compatible with all JA-6X control panels.

Specifications

Power	3 V - 2 x AAA battery 1.5V
Battery life time	about 1 year
Working frequency	433.92 MHz
RF Power	< 10 mV
Working range	max. 100 m (open area)

Specification of the Optex VX 402R detector

Detection method	Passive infrared
Coverage	12 m / 90° ; 14 segments
Mounting height	0.8 – 1.2 m
Detection speed	0.3 – 1.5 ms ⁻¹
Battery saving timer	5 or 120 seconds
LED indicator	only in the test mode

Environmental class	IV (EN 50131-1)
Operating temperature	-20°C to +50°C
Waterproof	IP54
Humidity	95%
Dimension	198 x 80 x 108 mm

Security grade	2 (EN 50131-1)
Can be operated according to	ERC/REC 70-03



Hereby, Jablotron Ltd., declares that this JA-60V is in compliance with the essential requirements and other relevant provisions of Directive 1999/5/EC.

Original of the conformity assessment can be found at the web page www.jablotron.cz, section Technical support.

Contents of the set: detector JA-60V, pole mounting kit, screw kit, area masking plates, 2 AAA batteries

Installation

Select the proper place for mounting the detector according to following:

1. Install the detector perpendicular to the ground to make upper detection area parallel to the ground
2. Installation height is 0.8 – 1.2 m
3. Mount the detector so that a majority of traffic flow is across the detection pattern
4. Too much light such as strong sunlight directed exactly to the sensor may cause unstable condition. It is highly recommended to avoid such installation.

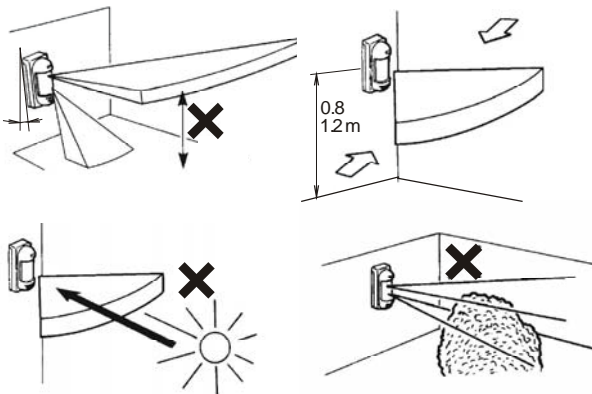

To open the detector:

1. Unscrew the lock screw and remove the top cover.
2. Unscrew the screws fastening the back box. Remove the back box.

NOTE: never touch surface of the PIR sensor.

Fix the detector to desired place. Detector can be fixed directly on the wall or by using supplied fix bracket on the pole (Ø 43 – 48 mm).

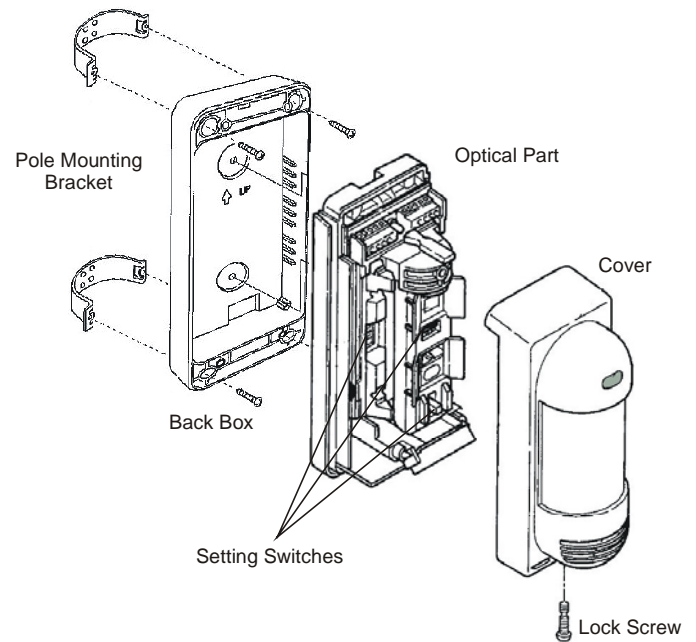

Enrollment of the detector to the receiver

The transmitter is placed below the optical part of the detector. Study the installation manual of the receiver unit (control panel) first to learn how enter the enrolling mode. When the receiver is switched to the enrolling mode insert the two provided AAA batteries into the detector (polarity is marked in the detector). The detector will generate an enrollment signal after the batteries are installed.

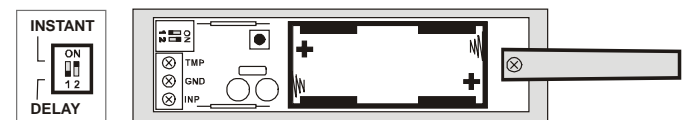

JA-60N transmitter

- Use DIP switch no. 1 to select the reaction of the system:
 - instant (position ON)
 - delay (position 1).
- Leave DIP switch no. 2 in position ON.

Adjustment

The upper detection area stays parallel to the ground. The lower area moves as shown below depending on the position of the setting switch. Detection length is therefore limited by the length of lower detection area, since both upper and lower detection area have to be activated at the same time to trigger the detector.

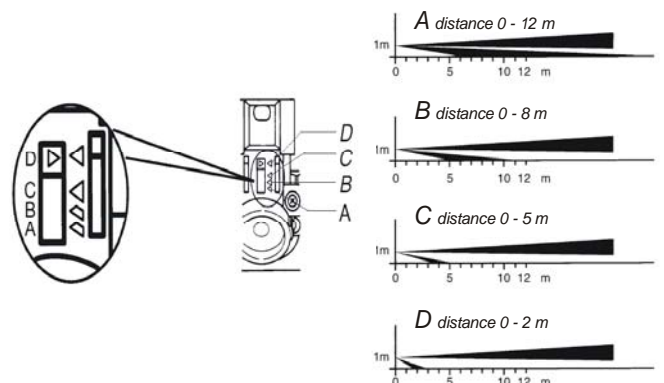

Detection length setting table:

Position	Max. detection length	
	Standard	See Note below
A	12 m	10.0 to 15.0 m
B	8 m	6.0 to 10.0 m
C	5 m	4.0 to 5.5 m
D	2 m	1.5 to 2.5m

NOTE: the maximum detection length may vary as above due to environmental thermal condition.

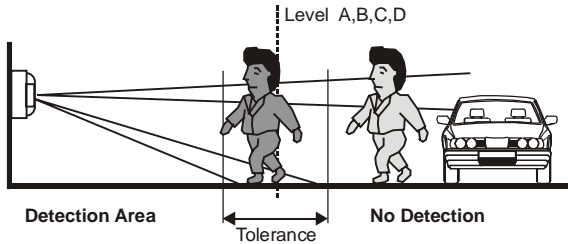

Active area angle is 90°. By holding the pyro-electric unit it can be turned in to desired direction (in 15° steps).

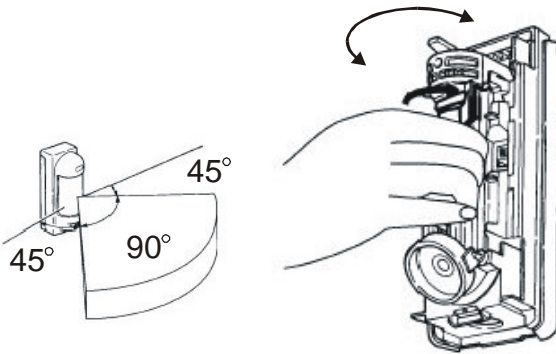

Area masking – by provided masking plates section of the detection area, which is exposed to the reflection of the sunlight, car light etc. can be masked.

Sensitivity of the PIR sensor can be set by “SENS” switch in three steps:

- L - low
- M - middle
- H - high

Other parameters can be set using a DIP switch:

LED indicator OFF	<input type="checkbox"/> 1	<input type="checkbox"/> NO	LED indicator ON
120 s	<input type="checkbox"/> 2	<input type="checkbox"/> 5	5 s Battery saving timer
4x	<input type="checkbox"/> 3	<input type="checkbox"/> 2	2x Pulse count

LED indicator is to be used for testing of the PIR detector. During normal operation period is recommended to switch it off to save the battery.

Depending on the 120s/5s battery saving timer DIP switch the movement sensor will be blocked for a period of 5 or 120 seconds after a movement is detected to conserves battery energy.

Depending on the Pulse count DIP switch the detector (both upper & lower detection area) must be triggered 2 or 4 times to transmit the alarm signal.

Operation test

Turn the LED indicator on, set the “battery saving timer” to 5 seconds and close the detector. Every 5 seconds any movement in the detection area will be indicated by the LED indicator and the alarm information will be sent to the control panel.

Operation

To increase batteries lifetime it is highly recommended to switch the “battery saving timer” to 120 seconds and switch off the LED indicator in normal operating mode. The movement sensor will be blocked for 5 or 120 seconds after a movement is detected. This means that if there is constant movement in the detection area the detector will transmit information about the movement only once every 5 or 120 seconds.

Battery testing and replacement

The detector automatically checks the condition of its batteries. If it is necessary to replace the batteries, the detector will inform the control panel about it. If a low battery is indicated the detector works as normal but, batteries should be replaced as soon as possible (within a week).

Before replacing the batteries, the control panel must be switched into mode, which allows detectors opening (User mode or Programming mode).

Use only high quality alkaline AAA batteries for replacement.

Note: Dispose of batteries safely depending on the type of the batteries and local regulation. Although this product does not contain any harmful materials we suggest you to return the product to the dealer or directly to the producer after usage.

Troubleshooting

Problem	Probable cause	Remedy
Detector makes false alarms	Lower detection area is unnecessarily long	Set the detection area properly
	Detector receives reflection of the reflector, sunlight, car light etc.	Remove the reflector, mask the area exposed to the reflection of light or change position of the detector
	There is a heat source in the area that can cause fast temperature change (stove, heater etc.)	Remove the source of heat or change position of the detector
Occasionally no detection	There is any moving object in the area (laundry on the clothesline, plants etc.)	Remove the moving object or change position of the detector
	Detection area is not set properly	Set the detection area properly
Detector fails to work	Sensitivity is set to low (L)	Change sensitivity to medium (M) or high (H)
	Low battery	Replace the battery
	LED does not light	Turn LED switch ON
	LED indicator lights but no reaction on the control panel	The control panel is out of range, check the battery, try to replace detector or control panel

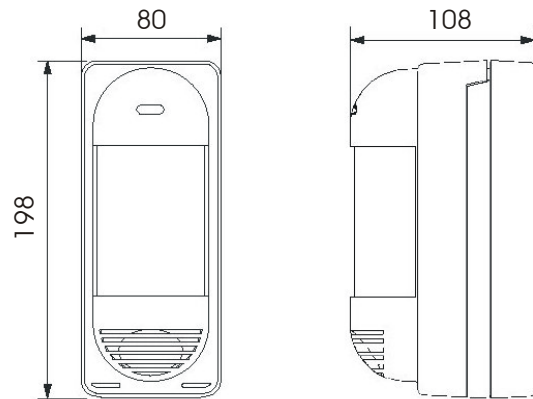

Dimensions



Note: Although this product does not contain any harmful materials we suggest you to return the product to the dealer or directly to the producer after usage.



Pod Skalkou 33
466 01 Jablonec nad Nisou

Tel.: 483 559 999

fax: 483 559 993

Internet: www.jablotron.cz